

**INSTALLATION PROCEDURE**

1. This tank is not designed to be subjected to vehicle loading. Wherever this is likely to occur, a load bearing cover slab should be designed by a qualified civil/structural engineer.
2. Care should be taken to fully access the ground conditions prior to commencement of installation.
3. All electrical work (where appropriate) should be carried out in accordance with regulations (eg NICEIC/Building Regulations).
4. Wherever there is a risk of high water table/saturated ground/flooding then appropriate measures should be taken to de-water the site during excavation & until such times as the installation is complete. In such conditions, the entire excavation must be lined with a continuous layer of 1200 gauge polyethylene sheeting which must be overlapped along the top and tied in to ensure that no water can penetrate the liner.
5. Concrete bed (minimum thickness 250mm with appropriate reinforcement to suit ground conditions) should be laid to uniformly support the entire base of the tank.
6. Lightly tamp and tank(s) onto wet concrete, ensuring the levels are correct and that the pipework and ducting is properly aligned.
7. Fill the tank(s) with clean water to a level of approximately 300mm (12") and recheck the pipework levels.

8. Commence backfilling evenly surrounding the tank(s) with a minimum of 150mm (6") concrete and haunching up around the base to a height of approximately 200mm (8").
9. Ensure there are no voids within the concrete. UNDER NO CIRCUMSTANCES SHOULD A VIBRATING POKER BE USED AND CONCRETE FALLING ON THE TANK(S) SHOULD BE AVOIDED WHEREVER POSSIBLE. If you contravene this warning you may damage the tank(s).
10. Continue filling the tank(s) with water whilst evenly backfilling with concrete, ensuring that the progressive water level remains approximately 300mm (12") above the concrete level.
11. Using appropriate formwork, continue pouring in lifts of 300mm (12") whilst ensuring that no voids form beneath or around the modules and pipework and allowing an initial set between each lift.
12. The concrete should completely encase the tank(s).
13. Manhole covers should be installed using a suitably designed cover slab to suit the appropriate loading.
14. THROUGHOUT THIS ENTIRE PROCEDURE IT IS ESSENTIAL THAT A DRY EXCAVATION IS MAINTAINED UNTIL THE FINAL POUR HAS SET. FAILURE TO DO THIS MAY RESULT IN VOIDS AROUND THE TANK(S) AND SUBSEQUENT TANK FAILURES.

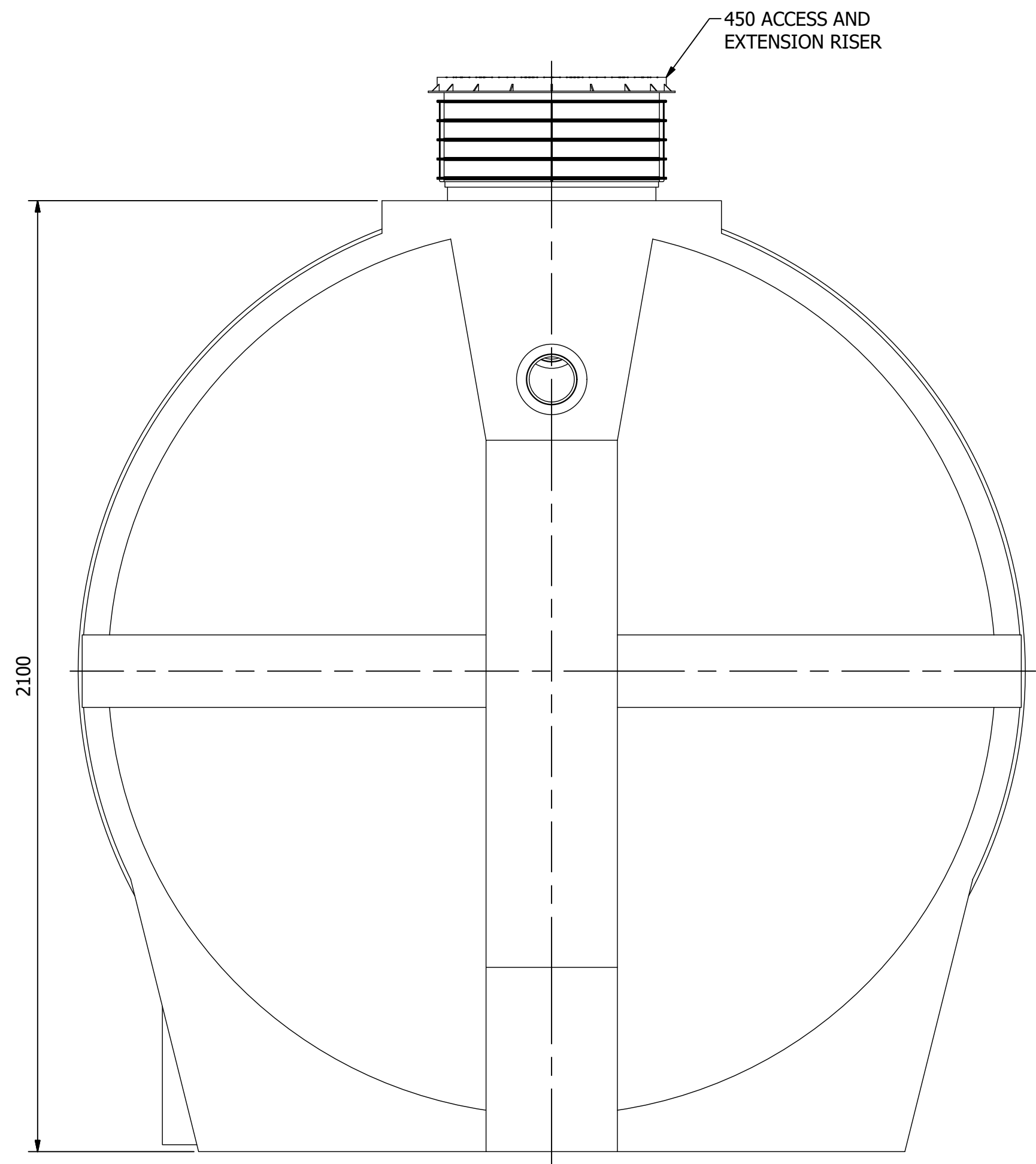

**PRODUCT INFO**  
 SINGLE PIECE ROTATIONALLY MOULDED  
 hdpe GREASE SEPARATOR  
 2500 x 2150 x 2100

INLET ..... Ø110 SOCKET EN1401  
 OUTLET ..... Ø110 SPIGOT EN1401  
 NOMINAL CAPACITY .. 5000 LITRES  
 SLUDGE CAPACITY ..... 2400 LITRES  
 FOG RETENTION ..... 1200 LITRES

SEPERATES AND RETAINS FATS, OILS AND GREASE (FOG's)

Please Note: All passive grease traps require regular service and removal of accumulated controlled waste for environmental disposal by registered waste carriers.

THIRD ANGLE PROJECTION  
  
 THIS DRAWING IS CONFIDENTIAL AND MAY NOT BE USED, COPIED OR DISCLOSED TO ANYONE WITHOUT THE PERMISSION OF ECOTEC

<b>ECOTEC</b> Ecotec, Clooncommons Castleconnell, Co Limerick V94PK00, Ireland		PRODUCT CODE <b>ETGS4</b>		PRODUCT DESCRIPTION <b>GREASE TRAP</b>			
Drawn By:	T.H.	Checked By:	G.M.	Approved By:	G.M.	REV	1
Drawn Date:	08/12/2020	Checked Date:	09/12/2020	Approved Date:	09/12/2020	SIZE	A3
						SHEET	1 OF 1
						SCALE	1:10