

**SPECIFICATION.**

MAX. EFFLUENT SEPERATION RATE ..... 0.5 LITRES/SECOND  
 DISCHARGE WATER OIL CONCENTRATION ..... <100 PPM  
 RECOVERED OIL WATER CONCENTRATION ..... <5%  
 MAX. DESIGN EFFLUENT CONCENTRATION ..... 90% OIL/10% WATER  
 OPTIMUM OPERATING TEMPERATURE ..... 30-40 °C.  
 HEATER ELEMENT ..... SINGLE PHASE 1.0Kw 240V THERMOSTAT CONTROLLED (DEFAULT TEMP. SETTING 35°C) HERT. 50 - 60

INLET ..... 40mm FEMALE FITTING  
 OUTLET ..... 40mm FEMALE FITTING  
 SILT OUTLET ..... 1" BSP FEMALE FITTING  
 OIL CASSETTE CAPACITY ..... 1.7 LITRES  
 CONSTRUCTION ..... 3mm 304 GRADE STAINLESS STEEL  
 WARANTY CONSTRUCTION ... 10 YEARS  
 HEATER WARRANTY ..... 1 YEAR  
 UNIT WEIGHT ..... 17.5 kg

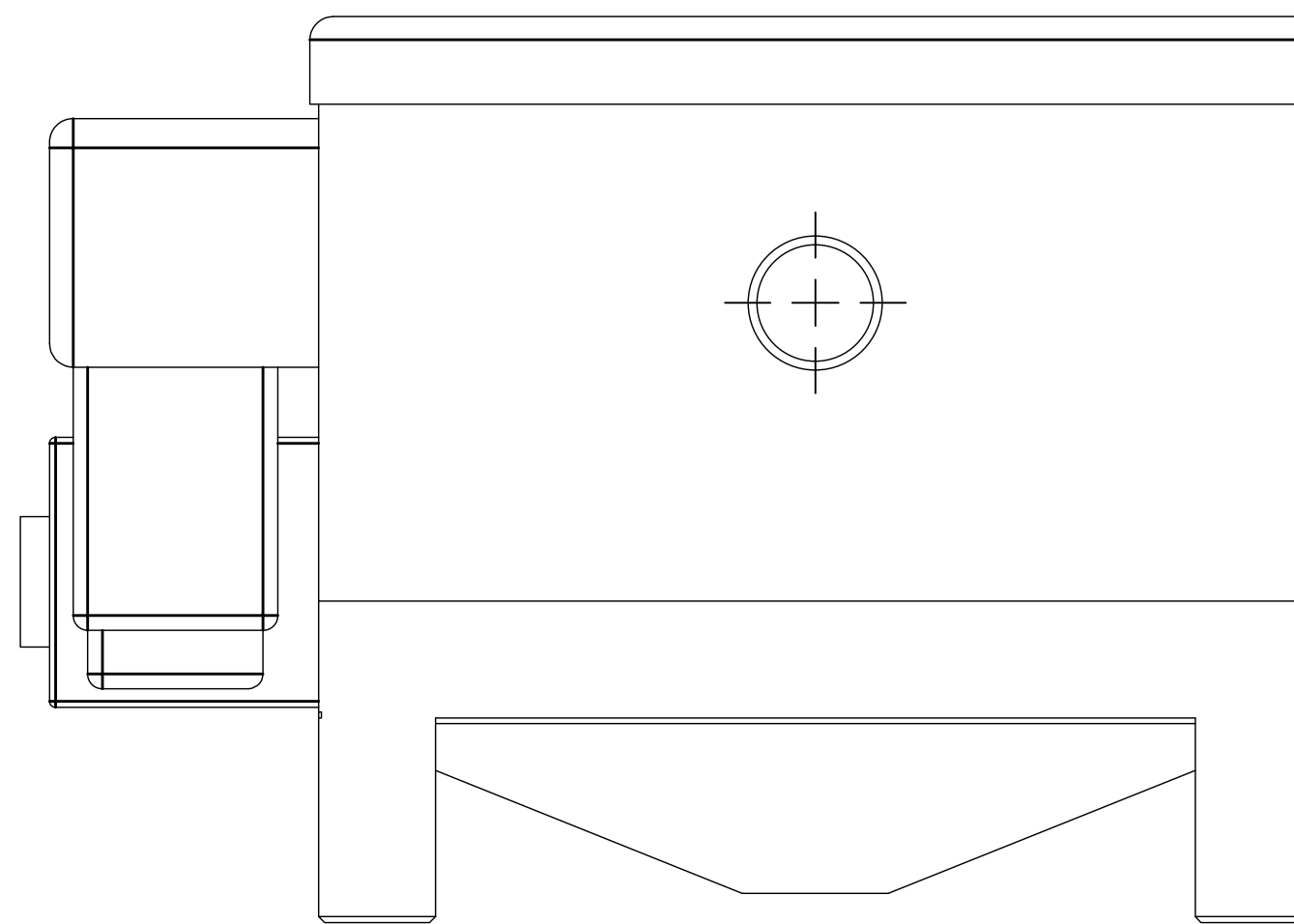
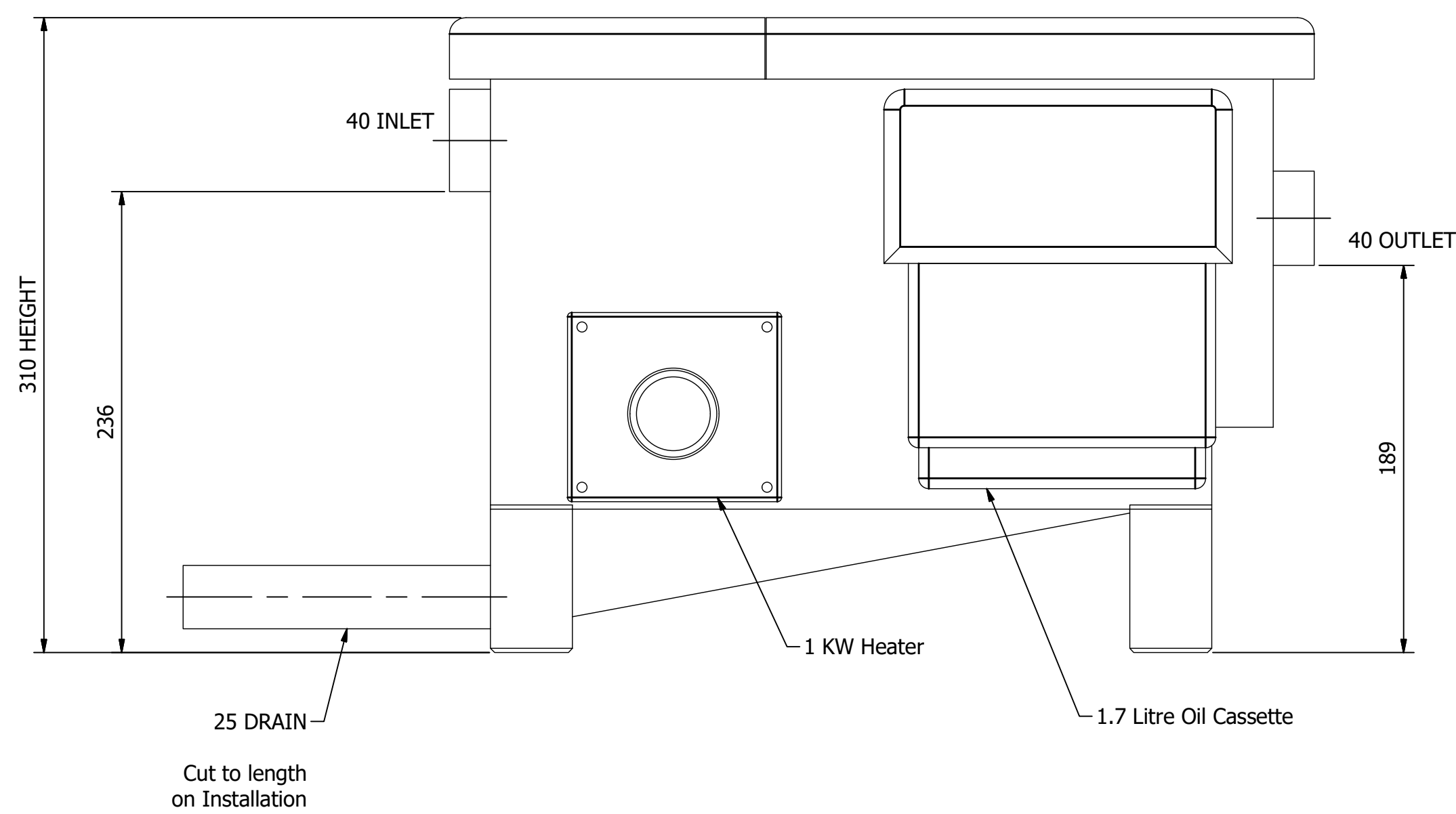
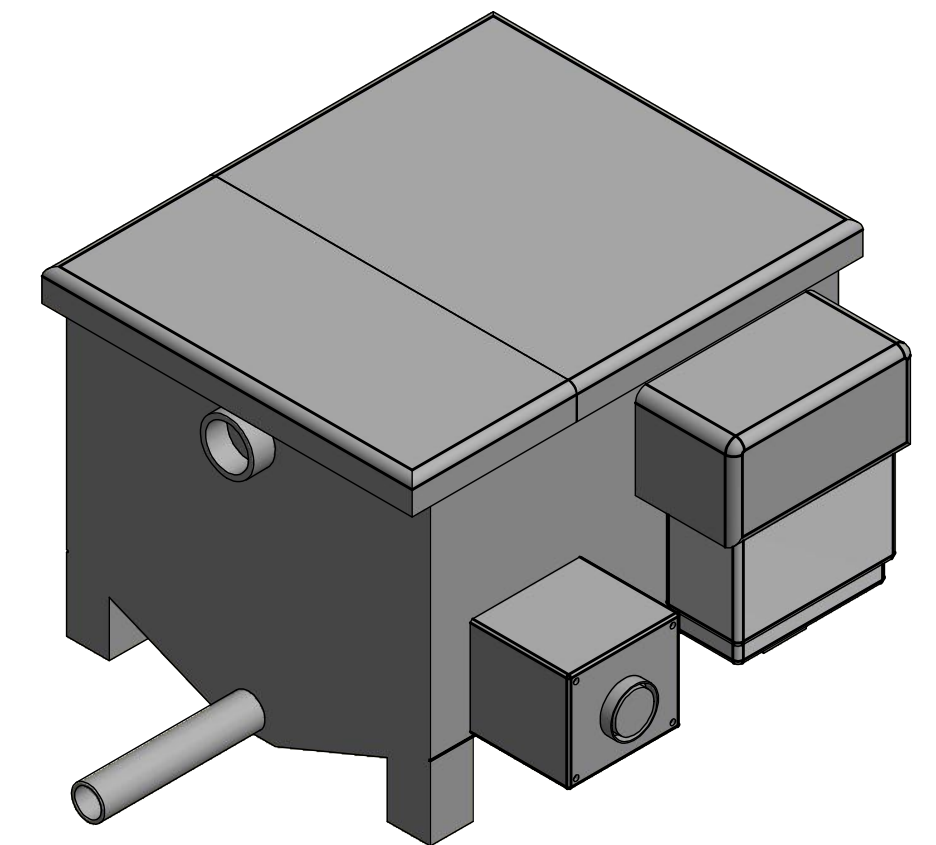
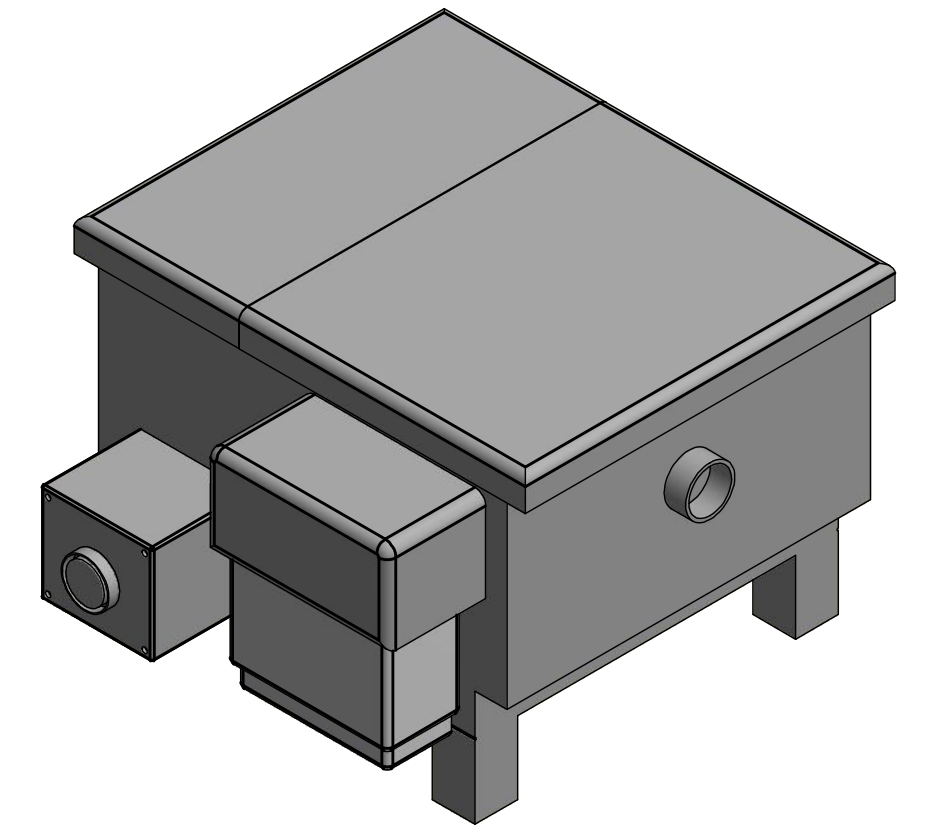

**NOTES.**

ETFS70 IS DESIGNED FOR USE IN SMALL KITCHENS OR ATTACHED TO SPECIFIC EQUIPMENT WITH FLOW RATE <0.5 Litres / Second.

ALL FATSTRIPPA PRODUCTS MEET THE REQUIREMENTS OF:-

UK APPROVED INDUSTRYACT 1991

APPROVED DOCUMENT H BUILDING REGULATIONS - DRAINAGE AND WASTE DISPOSAL, 2015 EDITION. BS.EN1825:2004 AND BS.EN1825:2002

DESIGNED IN ACCORDANCE WITH STANDARD PDI-G101

ENVIRONMENTAL PROTECTION ACT 1990 - FOOD SAFETY & HYGIENE REGULATIONS 2013 & EUROPEAN REGULATION (EC) No. 852-2004

CONSTRUCTION PRODUCTS REGULATIONS (CPR) REQUIREMENTS UNDER THE SCOPE OF HARMONISED EUROPEAN STANDARDS (hEN's) for CE MARKING

BS EN12056-1:2000 WITH REGARDS TO THE HEALTH AND SAFETY OF USERS AND OCCUPIERS AND THE PENETRATION OF TOXIC OR NOXIOUS OUDORS IN BUILDINGS.

**ECOTEC** Ecotec, Clooncommons  
 Castleconnell, Co Limerick  
 V94PK00, Ireland

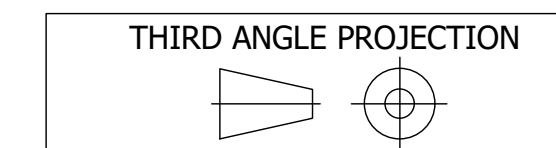

THIRD ANGLE PROJECTION

THIS DRAWING IS CONFIDENTIAL AND MAY NOT BE USED, COPIED OR DISCLOSED TO ANYONE WITHOUT THE PERMISSION OF ECOTEC

PRODUCT CODE		PRODUCT DESCRIPTION						
ETFS50		GREASE REMOVAL SYSTEM						
Drawn By:	T.H.	Checked By:	G.M.	Approved By:	G.M.	REV	1	SHEET 1 OF 1
Drawn Date:	15/12/2020	Checked Date:	15/12/2020	Approved Date:	15/12/2020	SIZE	A3	SCALE 1:2.5